

SCHOOL POLICE/SECURITY SYSTEMS



DSC Arm/Disarm

DSC 2013

DSC ARMING Partitions

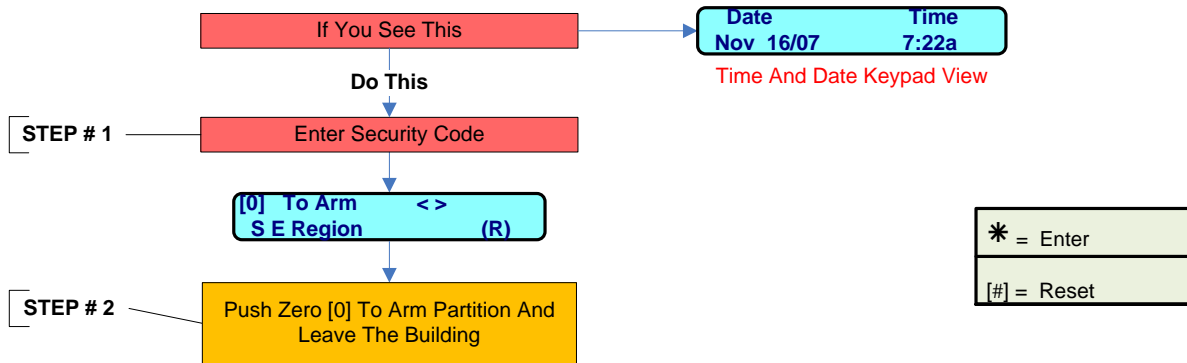

DSC DISARMING Partitions

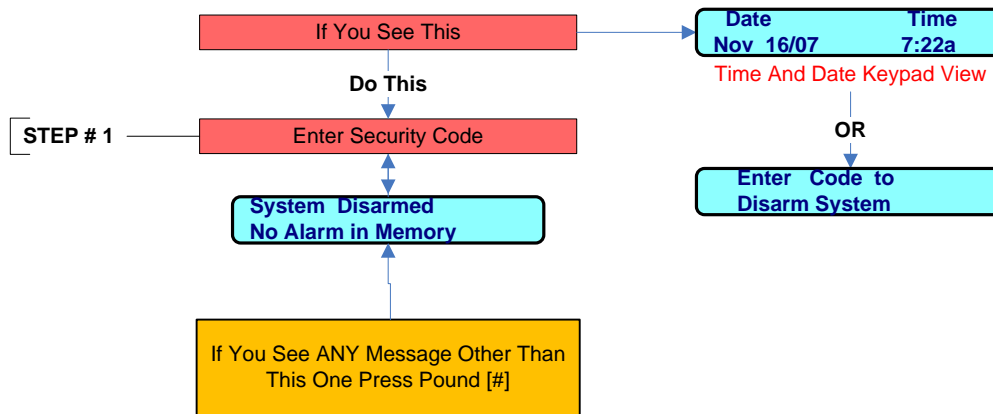

NOTE: If you make an error at any time, press '#' '#' and re-enter your Security Code.

Contact Information



**If you need additional assistance, please
contact us at:**



Help Desk: 799-1048



School Police: 799-5411

The CCSD Security Systems Help Desk is available Monday-Friday 7:00 am to 3:30 pm. If you are calling after normal hours, please leave a message and your call will be returned during normal hours.

Thank You.

1.0 RECORD RETENTION TABLE:

Identification	Storage	Retention	Disposition	Protection
SPD2-W002	CCSDPD website	Minimum of 5 years	Hard copy filed in folder in CCSDPD Security Systems	Server back-up

2.0 DOCUMENT REVISION HISTORY:

Date	Rev.	Description of Revision
04-Feb-2010	A	Initial Release of the document

3.0 PROCESS OUTPUT:

3.1 Step-by-step guide for arming/disarming of the Maxsys Digital Security Controls (DSC) alarm system with “simplified or forced arming” programming.

4.0 THIS DOCUMENT APPROVED BY (Reference Document Control Form):

4.1 Director of Security Systems